

MULTI-CHANNEL TIMED LEVEL CONTROLLER FOR MASKING NOISE, PAGING, AND MUSIC

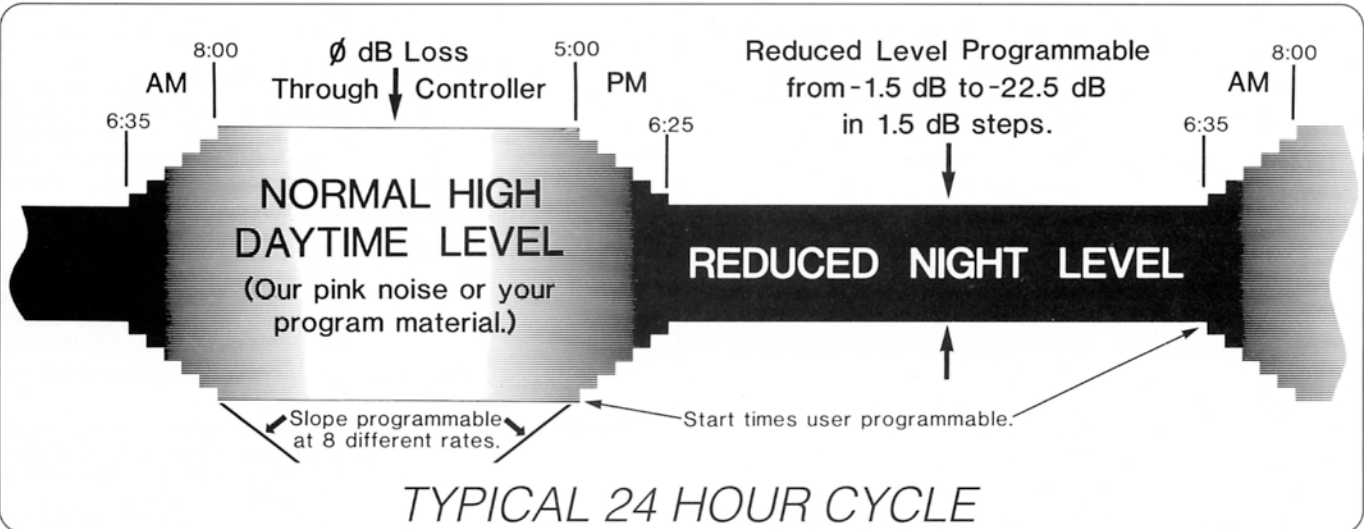

Timed level control maintains masking consistency where ambient noise and activity varies with the time of day.

- Fully field programmable from the front panel. "STANDBY BATTERY COVER" conceals programming controls to prevent program tampering.
- Tracking time/level control of up to 7 channels of any program material, 20Hz - 20kHz. (Masking & music levels should track)
- Noise generators are optional. 1-3 tracking channels of non-coherent pink noise. Two channel systems are typical.
- Full input and output transformer isolation: 10K Ω bridging inputs, 600 Ω outputs.
- Rechargeable battery backup standard. Battery is pulse load tested daily assuring reliable time keeping when power fails.
- POWER-UP level programmable for a *soft start*, eliminating instantaneous high level noise at turn-on after power failure.
- Optional **SLO-START** for automatic slow first-time turn-up of masking noise without costly return trips. Reduces the psychological impact of adding masking noise to occupied space.
- Programmable DAY INHIBIT holds the level at decreased setting on weekends or other user defined quiet days.
- Quartz clock accuracy, not influenced by power line variations.
- All solid state, no relays.
- Embodies the PATENTED process of time-controlled masking.

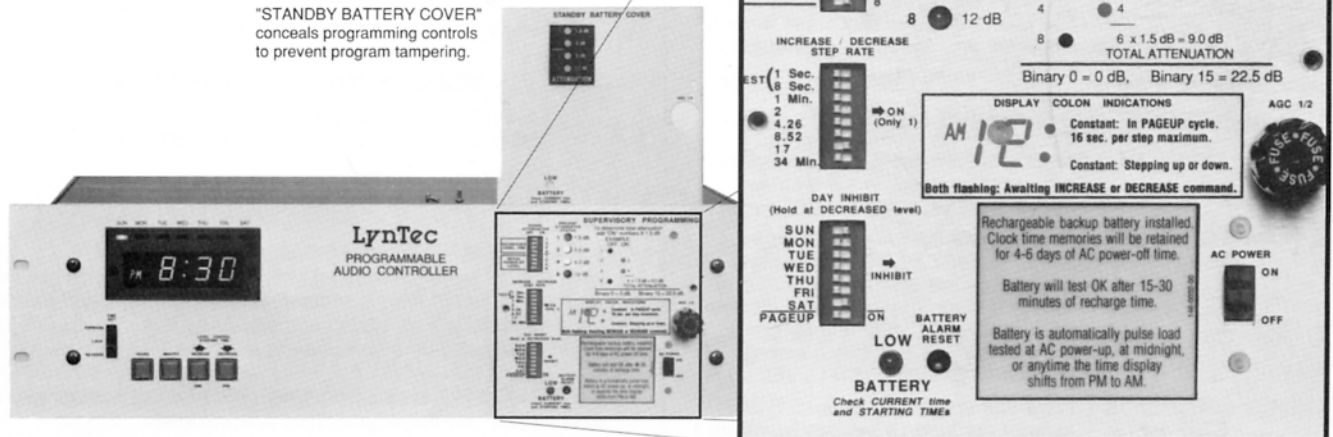

CONTENTS

Brochure sheetA

Table of Contents 1

Rear Panel Connections & Labelling 2

I NEVER read manuals..... 3

Functional Block Diagram. 4

Product Description & Functions 5-7

Description of Front Panel Controls 8

User Accessable Programming, Setup 9

Supervisory Programming 10-12

Correlation Chart

Attenuation vs Binary number 11

Quick performance test 13

Typical 2 Channel Masking System Diagram..... 14

Backup Battery Details 15

Specifications 16-17

Model Number Explanation 18

Retrofitting Additional Channels 18

Warranty 18

SLO-START option..... see label on page 2

LynTec PAC series

PROGRAMMABLE AUDIO CONTROLLER Rear Panel Connections & Labelling

All connections are to #6 barrier strip terminals.

SLO-START BOARD
Function: Raises level of masking noise output slowly (1.5 dB per day) at initial turn-on.

How it works: Slo-start senses the position of **POWER-UP LEVEL** dip switches on front panel and translates that binary number to 15. (22.5 dB which is full attenuation). Slo-start then decrements one count each day at midnight until the leds below match the front panel leds. The fuse then blows, deactivating Slo-start and extinguishing the yellow **Active** led.

NOTE: **POWER-UP LEVEL** dip switches should be set the same as **DECREASED LEVEL** for this Slo-start function.

Slo-start may be reactivated by replacing 1/16 Amp. fuse. →

The leds below mimic front panel leds when Slo-start is inactive.

These leds indicate the attenuation command being fed to all channels to the right of this board.

ATTENUATION				SLO-START ACTIVE
1.5dB	3dB	6dB	12dB	
BINARY NUMBER				
1	2	4	8	

SLO-START

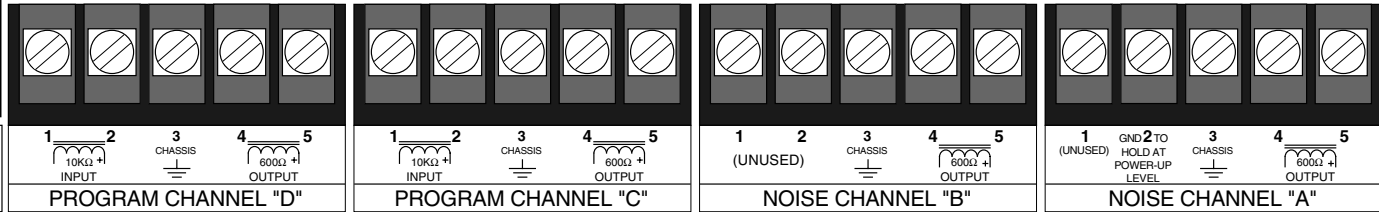

Typically used for background music

Typically used for paging audio

I NEVER read manuals

This page is for you.

The information contained in outlined boxes like this, scattered thru the manual, provides a no frills, fast-track method to run thru the controller setup.

These instructions outline the way we set up a unit to tell if it is functional. If you run thru these, we'll have something in common when you call us with questions.

We'll be glad to help. 800-724-4047

When all else fails read the manual.

FUNCTIONAL BLOCK DIAGRAM

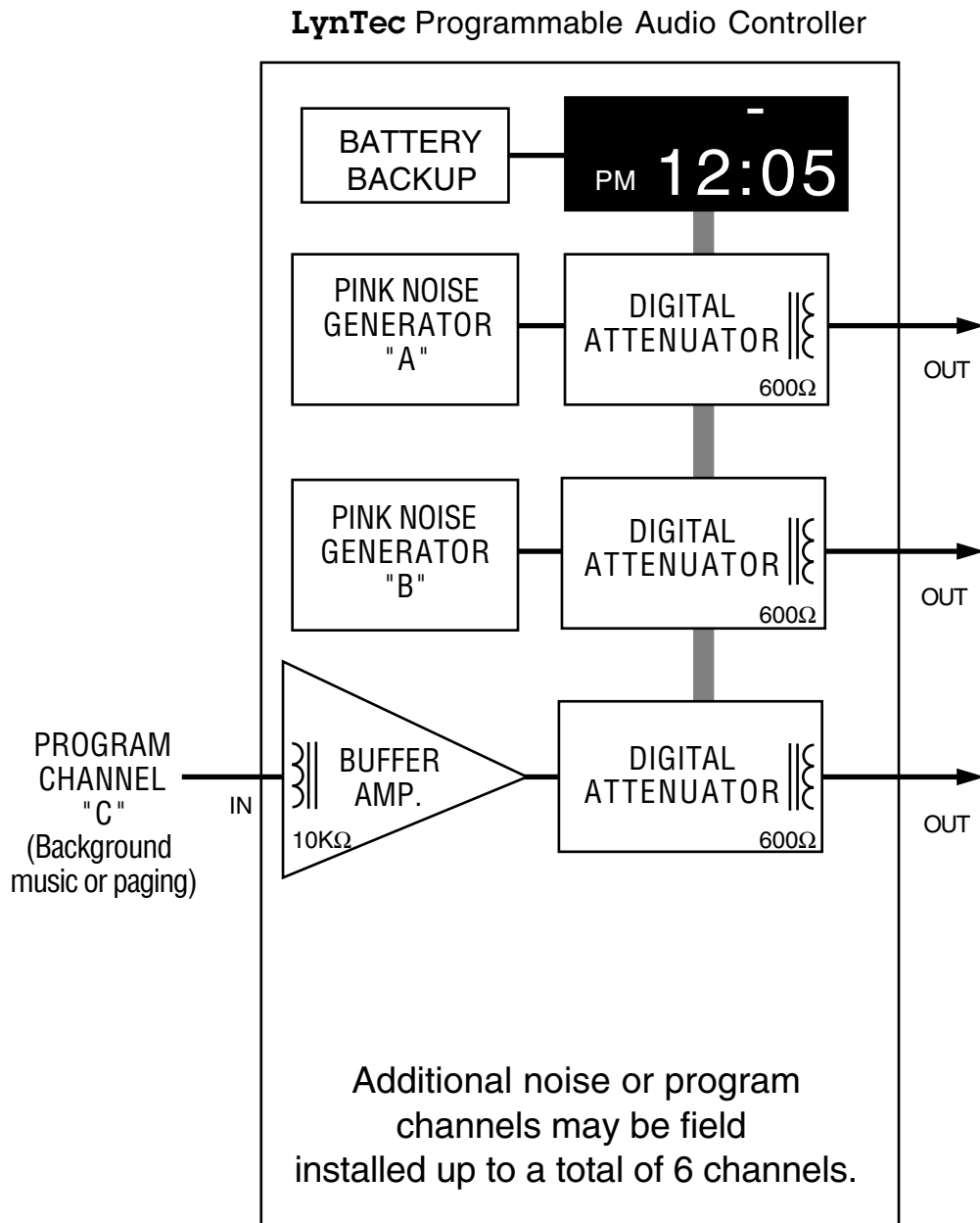

PRODUCT FUNCTIONS

Product description:

The programmable audio controller consists of a digital quartz clock normally reading the current time of day. The controller also has 2 user programmable preset **LEVEL CONTROL STARTING TIMES**, (1 in AM & 1 in PM).

Field programmable STARTING TIMES control level timing cycles

Each of these **STARTING TIMES** starts an up/down binary counter that drives up to seven digitally controlled audio step attenuators.

Each step attenuator will step in increments of 1.5 dB from 0 dB to 22.5 dB insertion loss. These attenuators may be used to control the output of optional built-in pink noise generators or to level control any other audio program material.

Variable STEP RATE sets level rise & fall times

The **RATE** at which the attenuators **STEP** up or down is programmable from 1 second to 34 minutes per step. A programmable **DAY INHIBIT** function is provided to keep the program or noise at the **DECREASED** level for those days requiring low levels such as weekends.

Battery backup

The controller is provided with a rechargeable battery back-up supply to retain timekeeping and set time data.

This battery back-up system uses a rechargeable sealed lead acid battery which is float charged by a temperature compensated charger. Expected life of the battery is 8-10 years.

The battery will keep the memory alive for 4 to 6 consecutive days of AC power line "down" time between recharges. A low voltage cutoff circuit prevents deep battery discharge if the controller is not AC powered for long periods.

To assure battery back-up integrity, the controller has a battery monitor. The battery is pulse load tested each day at midnight, on initial power-up and each time the display makes a PM to AM transition. A flashing **LOW BATTERY** alarm LED on the front of the unit alerts maintenance personnel that a low battery condition has occurred and the time memory may have been lost. The time and day display are illuminated only when AC power is applied.

POWER-UP after a power failure

In the event of a power failure, the program and noise levels are automatically reset to a field programmable lower **POWER-UP** level.

This feature prevents instantaneous high level noise or program material when the power comes back on.

When power is resumed after a power failure, the controller goes into the **POWER-UP** mode. The settings you set into the **POWER-UP LEVEL** switches command the controller to reset all of the attenuator channels to that level immediately on the resumption of AC power.

PRODUCT FUNCTIONS

(continued)

Where **POWER-UP** is normally set

Normally in noise masking systems the **POWER-UP LEVEL** is set a few dB below the **DECREASED LEVEL** setting so that even at night the noise will come up slowly after a power failure.

Example: DECREASE LEVEL: 6 (-9 dB), POWER-UP:10 (-15 dB)

SLO-START POWER-UP settings an exception

When the SLO-START board is used the **POWER-UP LEVEL** must be set the **same** as the **DECREASED LEVEL**.

The **STEP RATE** at which the level rises is the same rate that it normally goes up and down at. This is ideal when used with noise masking and background music systems where sudden large level shifts are offensive.

HOLD AT POWER-UP LEVEL function useful for emergency paging

All levels may be dipped to the **POWER-UP LEVEL** by connecting terminal 2 (A2) to terminal 3 (A3 is chassis ground) on the "A" NOISE channel. This function is useful to dip the masking level which in turn will reduce emergency paging audio power required. See Application Note 2 at back of manual for more details.

Quicker **POWER-UP** cycle for paging systems

Paging systems however, pose a new problem after a power failure. The paging needs to be restored soon after power resumes to be effective.

PAGEUP brings level back up at a 16 second per step rate

In the case where paging is run through the controller, the **PAGEUP** switch should be in the **ON** position. The **PAGEUP** switch introduces a 16 second **STEP RATE** to raise the level of all channels including the paging channel, only after a power failure or on **POWER-UP**.

This level change rate is slow enough to be heard only by those listening for it, but fast enough to get the paging back up to normal within a few minutes.

When the **PAGEUP** switch is **ON**, The 16 second **PAGEUP** step rate has priority at **POWER-UP** over slower **STEP RATES** from 8.52 to 34 Minutes per step.

(more about PAGEUP on next page)

PRODUCT FUNCTIONS

(continued)

Use only longer STEP RATES with PAGEUP

A conflict occurs when a step rate of less than 2 minutes is chosen. On **POWER-UP** the counter will seem erratic because it is getting two sets of inputs, one from the **STEP RATE** setting and one from the 16 second **PAGEUP** switch.

This symptom will only be evident at **POWER-UP** since that is the only time **PAGEUP** is active. **PAGEUP** should be used **only** with the **STEP RATE** set at **8.52, 17** or **34** Minutes.

How to tell if PAGEUP is active

You can tell if the controller is in a **PAGEUP** cycle by looking at the top dot of the colon located between the hours and minutes digits.

If the top and bottom dots are constant, the controller is in a **PAGE-UP** cycle.

Other colon indications

Both dots in the colon will flash after the power-up function is completed, indicating the controller is keeping time and awaiting a level change command.

A constant bottom dot indicates that the controller is in the process of stepping the level up or down.

Both dots will be held constant when "HOLD AT POWER-UP LEVEL" terminal (A2) on the rear is grounded.

Description of FRONT PANEL CONTROLS

(For user accessible programming)

TIME SET

This 3 position slide switch allows **FORWARD** or **REVERSE** setting of current time, **INCREASE** and **DECREASE LEVEL CONTROL STARTING TIMEs**. The **LOCK** position inhibits all time setting.

HOURS

This button is used to set the **HOURS** digits when the **TIME SET** switch is in the **FORWARD** or **REVERSE** position.

MINUTES

This button is used to set the **MINUTES** digits when the **TIME SET** switch is in the **FORWARD** or **REVERSE** position.

NOTE: At initial power-up, timekeeping will not begin until the **MINUTES** button is pressed with the **TIME SET** switch in the **FORWARD** position.

LEVEL CONTROL STARTING TIMEs

INCREASE (AM)

This button will display the **STARTING TIME** of the level **INCREASE**. The starting time may be reset with the **HOURS** or **MINUTES** buttons while holding down the **INCREASE** button if the **TIME SET** switch is in the **FORWARD** or **REVERSE** position. The **INCREASE** start time **MUST** be in the **AM**.

DECREASE: (PM)

This button will display the **STARTING TIME** of the level **DECREASE**. The starting time may be reset with the **HOURS** or **MINUTES** buttons while holding down the **DECREASE** button if the **TIME SET** switch is in the **FORWARD** or **REVERSE** position. The **DECREASE** start time **MUST** be in the **PM**.

Setup of FRONT PANEL CONTROLS

(user accessible programming)

Initial power application

When initial power is applied, the clock will show the current time, if memory has been retained, or read 12:00 if memory has been lost. If memory has been lost; **The clock will not start, nor will the ATTENUATION LEDs stop cycling until the MINUTES button is pressed in the FORWARD position.** The red **LOW BATTERY** LED may also flash. Don't worry about that, we'll get to it later.

One or more of the day of the week LEDs may be lit on initial power-up. The bottom dot of the colon will remain constant until the **POWER-UP** cycle is finished and then flash to denote counter and clock activity. (see DISPLAY COLON INDICATIONS on panel)

Setting day of week

The display should then be set for the proper day of the week. Switch the **TIME SET** to the **FORWARD** position. Press the **HOURS** button, cycling the display to advance to the proper day of the week. (The day of the week counter will not reverse.)

Short cut method: Advance from 11 PM to 12 AM with **TIME SET** in **FORWARD** using **HOURS** button. When the transition from PM to AM occurs, the day will advance. Reverse the function by switching to **REVERSE** and backing up to 11 PM then back to **FORWARD** to advance a day by going to 12 AM. Jogging back and forth will advance day quickly without waiting for 24 hour steps.

Setting the current time

Next, set the current time of day with the **HOURS** and **MINUTES** buttons.

Setting the INCREASE starting time

Next, we're ready to set the **INCREASE** starting time. This time **must** be in the AM. Hold the **INCREASE** (AM) button down and set the time with the **HOURS** and **MINUTES** buttons.

1st time: Set this time at 11:58 AM.

Setting the DECREASE starting time

Next set the **DECREASE** starting time the same way using the **DECREASE** (PM) button, this time **must** be PM.

1st time: Set this time to 12:01 PM.

Daylight saving time

If you do not wish to reset the controller's current time on the first Sunday of April and the last Sunday of October, you may want to compromise by "straddling" the hour difference with your **INCREASE** and **DECREASE** STARTING TIMES.

This concludes the user accessible programming.
All other programming is considered "Initial set-up or Supervisory".

SUPERVISORY PROGRAMMING

The **SUPERVISORY PROGRAMMING** provides field programmability for the control of specific amplitude levels and rates of change as well as **INHIBIT** days. All supervisory controls are located behind the "STANDBY BATTERY COVER" plate. Programming the dip switches requires teeny fingers or preferably a hollow tool like the open end of a retracted ball point pen.

SIGNAL ATTENUATION

In the top cutout there are 2 sets of four switches, each controlling the number of steps of attenuation that are switched in.

DECREASED LEVEL (PM)

The top four determine the **DECREASED LEVEL (PM)** of all attenuator channels. Remember that the "daytime" level is 0 dB of attenuation.

1st time: Confirm the factory shipped setting of 6. (2 + 4).

INITIAL POWER-UP LEVEL

The bottom four determine the **INITIAL POWER-UP LEVEL** of all attenuator channels when AC power is restored.

1st time: Confirm the factory shipped setting of 15. (1 + 2 + 4 + 8) All 4 switches ON [except when SLO-START is installed: 6 (2 + 4)]

These switches are binary coded.

To determine the attenuation you must add the total binary value and multiply the sum by 1.5 dB.

EXAMPLE:

Binary value	OFF	ON	Attenuation
1	*		1.5 dB
2		*	3.0 dB
4		*	6.0 dB
8	*		12.0 dB
Binary total		<u>6</u>	6 x 1.5 dB per step Total attenuation = 9.0 dB

(SEE NEXT PAGE FOR COMPLETE CORRELATION CHART)

SUPERVISORY PROGRAMMING

(continued)

PRESENT ATTENUATOR STATUS

These 4 LEDs indicate the binary code presently being fed to ALL of the programmable attenuators. ALL attenuator channels have the same range of attenuation and rate of control.

CORRELATION CHART

Attenuation for Binary number total
(switch combination shown in parenthesis)

1.5 dB.....	1
3.0 dB.....	2
4.5 dB.....	3 (1 + 2)
6.0 dB.....	4
7.5 dB.....	5 (1 + 4)
9.0 dB.....	6 (2 + 4)
10.5 dB.....	7 (1 + 2 + 4)
12.0 dB.....	8
13.5 dB.....	9 (1 + 8)
15.0 dB.....	10 (2 + 8)
16.5 dB.....	11 (1 + 2 + 8)
18.0 dB.....	12 (4 + 8)
19.5 dB.....	13 (1 + 4 + 8)
21.0 dB.....	14 (2 + 4 + 8)
22.5 dB.....	15 (1 + 2 + 4 + 8)

SUPERVISORY PROGRAMMING

(continued)

INCREASE / DECREASE STEP RATE

These 8 switches determine the rate of attenuation change, both increasing and decreasing.

The top two, 1 & 8 seconds per step, are used only for testing the system, as fast step changes are more likely to be noticed by the building occupants.

Only **one** of these 8 switches should be on at any time. NOTE: the total number of steps must be completed within the AM or PM. Be sure that when you program these switches, the cycle is completed before midnight for the **DECREASE** and before noon for the **INCREASE**.

This cycle time will be the binary total of the **DECREASED LEVEL** switches in the "ON" position times the minutes per step set on the **INCREASE/DECREASE STEP RATE** switch.

1st time: Confirm the factory shipped setting of 1 second.

DAY INHIBIT (Hold at DECREASED level)

These 7 switches are used to hold the attenuation at the **DECREASED** level all day in the **INHIBIT** position. An example would be to **INHIBIT** on Saturday and Sunday to hold the masking noise/program level low during low occupation or low activity days.

1st time: Confirm the factory shipped setting of ALL OFF.

PAGEUP

PAGEUP is a power-up command to step at a maximum of 16 seconds per step, restoring those systems with paging to their original "pre-power failure" level quickly but not instantaneously.

In the **ON** position, **PAGEUP** holds priority over the 8.52 to 34 Minute step rates, but only at power-up. In the **OFF** position, the power-up step rate is that selected by the **STEP RATE** switches.

Typical **PAGEUP** settings: Masking noise systems only = OFF.
Any system with paging = ON.

NOTE: **PAGEUP** will appear erratic at step rates of 4.26 minutes or less and should **only** be used at 8.52, 17 or 34 Minutes per step.

QUICK PERFORMANCE TEST

1st time: You now have twiddled or confirmed the settings of all of the controls and should know what they do. The following quick checks exercise the controller to show you in accelerated fashion what happens for a full cycle.

Advance the current time of day to 11:58 AM with the **HOURS** and **MINUTES** buttons.

Direct your attention to the **PRESENT ATTENUATOR STATUS** LEDs just to the right of the top dip switch window. One or more of the LEDs may be lit, if they are, wait for LEDs to run through a cycle, counting down at a 1 per second rate until all lamps are off. When all lamps are off, each channel has 0 dB feed through attenuation.

Advance the current time of day to 12:01 PM. The lamps will now count up to a binary total of 6 and stop. Each count up adds 1.5 dB of attenuation in all channels.

Turn the **AC POWER** switch **OFF**, wait a few seconds and turn it back on. The same current time should appear, indicating that the battery back-up did its job. The **LOW BATTERY** light may start flashing if the battery hasn't had time to recharge.

When the **AC POWER** is switched back on, all **PRESENT ATTENUATOR STATUS** LEDs should light, indicating that a binary number of 15 is set into the counter on power-up. The counter will count down from 15 to 6 and stop because that was the **DECREASED** level setting that was evident when the AC power failed.

If the power had failed between 11:58 AM and 12:01 PM the counter would have started at 15 and counted down to zero because after 11:58 AM the level was **INCREASED**.

Zero (all LEDs off) is always the **INCREASED** level, because there is zero attenuation. All of the controller channels have 0 dB attenuation at binary zero and 22.5 dB attenuation at the binary number of 15.

As you cycle the current time with the **HOURS** button, the DAY LEDs, (above the clock display), should advance when the **PM** goes to **AM** (midnight). The day of the week counter will not reverse. The day of the week counter will not advance when setting or checking the **INCREASE** or **DECREASE STARTING TIMES**.

Now that you've seen how it works you can set in your own parameters.

BOLD FACE = Front panel nomenclature

Typical 2 channel Masking System

Mixed music and paging is time/level controlled at the same rate as the masking assuring day/night consistency.

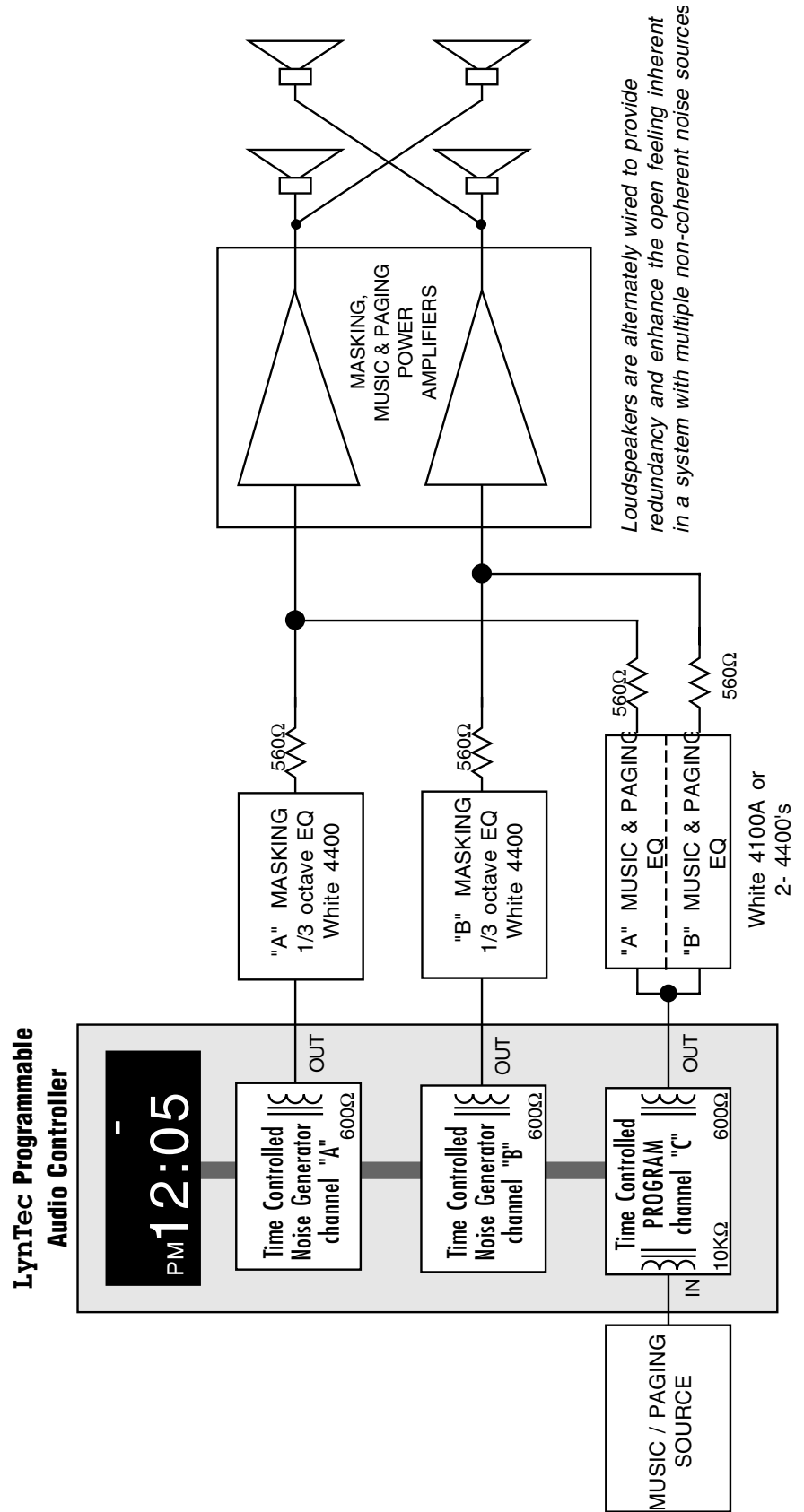

BACKUP BATTERY DETAILS

STANDBY BATTERY

The built-in standby battery will need time to recharge if the controller has been powered down for more than 4 to 6 days. The time memory may be lost because the battery circuit has a low voltage cutoff to prevent battery damage due to deep discharge.

The battery is automatically pulse load tested periodically. The pulse load test applies a high current load ten times the normal standby requirement for a half second while monitoring the voltage to determine the battery integrity.

Two different events will trigger the pulse load test. Resumption of AC power or the transition of the time display from PM to AM.

This transition method assures a test at midnight and also during the time setting process or when you check the **INCREASE** or **DECREASE** starting times.

What to do if you find the **LOW BATTERY** light flashing

Press the **BATTERY ALARM RESET** button. The **LOW BATTERY** LED should stop flashing.

Once you reset the alarm, it normally will not retrigger because the battery charger will provide enough current to charge up the battery sufficiently to pass the next pulse load test at midnight.

The **LOW BATTERY** LED may begin flashing again during initial time setting when the display makes **PM** to **AM** transitions, if the partially recharged battery fails the automatic pulse load test.

The battery should test O.K. after 10-15 minutes of recharge time.

The battery charger does not supply enough current to pass the high current pulse test, the battery must be good to pass the test. A battery charger failure and battery discharge allowing the open circuit voltage to fall below 9.6 volts will trigger the alarm immediately.

In any case the alarm latches and will flash until you do something about it. Battery replacement will require removal and dis-assembly of the controller. Batteries are replaceable in the field by removing the side panel on the AC POWER SWITCH side.

2 each Hawker (Gates) Monobloc 0819-0012, 6v @ 2.5AH are required.

<http://www.batterystore.com/Hawker/HawkerMonoblocs.htm>

*2/2006:
LynTec no longer
stocks the recharge-
able batteries.*

*Our recommendation
is to power the PAC
from an inexpensive
UPS power supply
available at computer
stores.*

*The smallest and
cheapest will easily
power the PAC during
a power outage.*

*Just ignore the Low
Battery LED flashing.*

SPECIFICATIONS

Number of time controlled channels:	2 standard with 5 additional optional.
Program channel audio input impedance:	9 to 18 kohms balanced. (10K Bridging transformer) If noise sources are specified, channel "A" & "B" inputs will be internally connected to noise sources without input bridging transformers. Outputs of "A" & "B" noise channels are transformer isolated to feed 600 ohm lines.
Maximum input level: [clip point]	3.9 volts RMS sine wave, 20 Hz-20 kHz. (+14dBm, 600 ohms)
Audio output (all channels):	Transformer isolated output to feed 600 ohm line. (Typical output impedance is 275 ohms at 1 kHz.)
Maximum output level: [clip point]	+14 dBm (3.9 volts RMS sine wave, 20 Hz-20 kHz.)
Normal operating levels:	
Noise channels:	0 dBm RMS (0.775 volts RMS) [14 dB headroom]
Program channels:	-10 dBm (0.245 volts RMS) [24 dB headroom]
Program channel frequency response:	±2 dB, 20 Hz-20 kHz, 0dBm.
Residual hum & noise:	75 dB or more below maximum output. (20 Hz to 20 kHz)
Added distortion:	Less than 0.5% total harmonic distortion added.
Time controlled attenuation:	Attenuation programmable from 0 to 22.5 dB in 1.5 dB steps.
Attenuation at 0 step (program channels):	0 dB within ±0.1 dB.
Attenuation accuracy:	Within 0.4 dB of step setting.
Channel to channel attenuator tracking accuracy: (for stereo applications)	Within ±0.2dB.
Channel to channel crosstalk rejection:	More than 80 dB.
POWER-UP:	Allows "soft start" after AC power failure. Level separately programmable from 0 to 22.5 dB in 1.5 dB steps.
HOLD AT POWER-UP LEVEL:	Used to reduce the output of all channels of the controller during emergency paging. An external contact closure across NOISE channel "A" terminals 2 & 3 will "HOLD AT POWER UP LEVEL". (see Application Note 2 at rear of manual) Only available on noise generating controllers.
Rate of control:	Programmable from 1 second to 34 minutes per step. 8 settings available: 1 & 8 seconds for setup testing, 1, 2, 4.26, 8.52, 17 & 34 minutes per step.

Due to technical progress and product improvement, specifications are subject to change without notice.

SPECIFICATIONS

(continued)

Noise generators:	2 independent pink noise generators standard, located on the channel "A" & "B" attenuator boards. The noise is produced by digital simulation with sequence limiting to reduce "thumping". The typical cycle time is one minute.
Noise generator output level:	0 dBm RMS into 600 ohm load. Flat within ± 2 dB from 63 Hz to 16 kHz. (As measured with a constant percentage bandwidth analyzer)
Controller clock:	Quartz crystal controlled. 12 hours, AM & PM are displayed on a low voltage fluorescent display. Day of the week is displayed on 7 individual green LED's.
Clock accuracy:	1 minute/month.
Clock setting resolution:	1 minute.
Controller power requirements:	105-125 volts AC, 50-60 Hz, 15 watts maximum.
Standby power:	Sealed lead acid standby battery, maintains time & day integrity during AC failure of up to 4-6 days. On resumption of AC power, the recharge time required for the battery to test O.K.: ≤ 15 minutes. All displays are inactive during AC failure.
Expected battery life:	8-10 years and is field replaceable as an assembly.
LOW BATTERY alarm:	A flashing red LED on the front panel indicates a LOW BATTERY condition has occurred and the time memory may have been lost. A concealed BATTERY ALARM RESET button is located adjacent to the LED to reset the alarm after battery recharge.
Standby power confidence:	The standby battery is float charged continuously and is pulse load tested each day at midnight, immediately upon resumption of AC power after power failure and each time the display makes a PM to AM transition. (Time setting or time checking)

MECHANICAL SPECIFICATIONS

Standard EIA rack panel mounting	Width: 19.00 inches, Height: 5.25 inches, Depth behind mounting surface: 10 inches maximum. Extension forward from mounting surface 1.0 inch maximum. Weight: 15 pounds maximum.
Audio connections:	Audio connections are on #6 barrier strips located on the rear panel.
Power Connections:	Attached 5.5 ft., 3 conductor power cord supplied.
Environmental:	Maximum ambient temperature: 110° Fahrenheit.
Maximum relative humidity:	80%.
Minimum operating temperature:	40° F.

DO NOT INSTALL IN TOP OF HOT POWER AMPLIFIER RACK !!!

Installation in a power amplifier rack with a cooling fan that holds the ambient temperature below 110° is OK IF the fan isn't too close to the controller.(See next paragraph)

Like all low level transformer coupled audio systems this equipment should be kept at least 6 inches from devices producing high magnetic fields such as power transformers, fans or solenoids. More physical isolation lessens the chance for hum problems.

MODEL NUMBER EXPLANATION

	Prefix (all models)	Attenuator Channels	Noise Sources	Special Modifications or options
Example:	PAC -	4A	2N	XX

A model PAC-4A2N would have **4** total **Attenuator** program channels, "A", "B", "C", & "D". Channels "A" & "B" would be fed directly from **2** internal pink **Noise** sources. Channels "C" & "D" would have bridging input transformers and would normally be used for program material.

A model PAC-6A would have **6** identical bridging input **Attenuator** channels, "A" thru "G", and no noise generators.

A model PAC-6A **TR** would be the same as the PAC-6A described above but modified so that it could be programmed to decrease in AM and increase in PM. **TR** = **T**ime **R**eversed.

A model **PAC 3A2N SS** would have **2** **Noise** sources fed through 2 of the **3** **Attenuator** channels. The 3rd **Attenuator** channel would be a program channel. **SS** denotes that a **SLO-START** board is installed to bring the noise up slowly at initial turn-on.

ADDITIONAL CHANNELS MAY BE ADDED IN THE FIELD

Additional attenuator boards may be added in the field, up to a total of 6 attenuator channels is possible. The addition of new attenuator channels requires a new daisy chain flat interconnect cable in addition to the new attenuator board. Please specify the **TOTAL** number of attenuator boards to be used after modification and the unit serial number that is being modified.

LIMITED WARRANTY

All LynTec products are warranted to be free from defects in workmanship and materials for a period of 15 months from the original invoice date. Warranty status may be found on the serial number label which shows the warranty expiration date. This warranty shall be limited to the repair, adjustment and/or replacement of defective parts including batteries.

LynTec will repair or replace defective LynTec products only at the factory at 8401 Melrose Drive, Lenexa, KS 66214. Phone 800-724-4047. All Returns are to be prepaid. LynTec will pay return UPS charges on warranty repairs. All excess transportation charges will be borne by the customer.

LynTec will not be responsible for inconveniences or consequential damages occasioned by LynTec equipment, or by breach of any express or implied warranty with respect thereto.

Implied warranties on this product shall be in effect only for the duration of the express warranty set forth above. After the warranty expiration date shown on the serial number label, there shall be no warranties, express or implied on the product.

This warranty becomes void if the product shows evidence of mishandling, tampering, battery or chemical corrosion, fire, water or lightning damage or other acts of nature, use contrary to the applicable instruction manual, shipping damage or repair performed by others.